

Kseries K215BII K215BAII

Sub-woofer System

K215BII is a dual 15" subwoofer, designed for bass reinforcement to K312 made of high quality plywood with polyurea waterproof paint. K215BAII is equipped with BA2.88 digital amplifier module to be an active subwoofer based on K215BII.

K215BII是一款双15"超低音箱。采用两只15"低音单元，倒相与前置号角结合结构设计，箱体采用多层复合夹板，聚脲喷涂。K215BAII是在K215BII的基础上配置BA2.88功放组件成为有源音箱。



CONFIGURATION

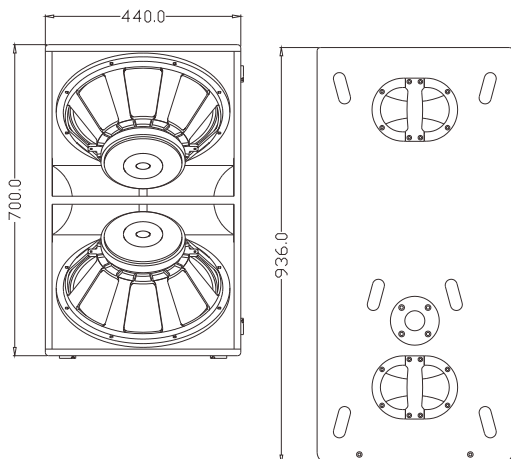

FEATURES

- High quality plywood with polyurea waterproof paint
- Bass reflex and horn-loaded design
- Top hat fitting for pole mounting to K series
- To match K312

产品特点

- 高质量单元配置，高强度夹板箱体
- 倒相与前置号角结合设计，高声压输出
- 超长品质保证期：品质与信心的保证

适用范围

- 用于中远程扩声
- 流动演出、剧院
- 配合K312使用，提升低频表现

MODEL

FREQUENCY RESPONSE(-3dB)

DRIVERS

RATED POWER

SENSITIVITY

MAXIMUM SPL

IMPEDANCE

INPUT CONNECTORS

PACKAGE SIZE

NET WEIGHT

GROSS WEIGHT

K215BII

40Hz-200Hz

2×15"(385mm)/4"voice coil LF

1200W RMS,4800W peak

101dB 1watt/1meter

132dB continuous,138dB peak

4 ohms nominal

2×Speakon NL4

1026mm×532mm×795mm

55 kg/pc

62 kg/pc

K215BAII

40Hz-200Hz

2×15"(385mm)/4"voice coil LF

1200W/4Ω+1200W/4Ω

--

132dB continuous,138dB peak

--

INPUT TYPE: Balanced Differential line

1026mm×532mm×795mm

57 kg/pc

64 kg/pc